

CLAAS
LEXION 480





Place your harvest in the most competent hands.

Reap all that you sow.

As the grain ripens and you see that the yields are as they should be, you realise that all the efforts of the past months have been worthwhile. Now the most vital phase is heading towards you – the harvest. A time of year where nothing seems to go quite to plan. The harvest area seems to be even larger than you imagined, the weather turns bad and you end up combining into the night. This is the moment that you need a highly productive combine that is 100% dependable, one like the LEXION 480, the flagship in the CLAAS combine fleet.

CLAAS is the first choice in the harvest.

CLAAS has a long tradition at the forefront of combine development. The LEXION 480 is the culmination of these efforts. Since its introduction, the LEXION 480 has set the standards in terms of performance at a level that is unchallenged to this day. It is a highly versatile combine with the lowest cost per ton when employed over large areas. The harvest is finished faster and the crop quality is always superb.

A tradition of innovation.

CLAAS pioneered the development of combines for European conditions, starting back in 1930. The company has consistently set the pace in the development of new ideas since then. Today's customers are looking for machines that are designed to cope with modern crop developments. In addition farmers expect a consistently high level of performance in all crop types with a minimum of wasted time between tasks. These demands are catered for by CLAAS and the LEXION 480 with many unique features such as AUTO CONTOUR cutter bar guidance system, VARIO cutter bars, LASER PILOT automatic steering, the revolutionary APS threshing unit, ROTO PLUS rotor separation and 3 D dynamic slope compensation.

The combination of all these features makes the LEXION 480 what it is. The world's most productive combine, with top performance from the beginning to the end of the harvest. It's the combine that takes the unpredictability out of the harvest.

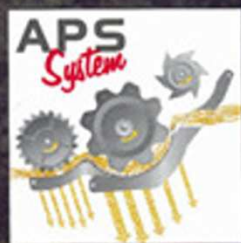



CLAAS
LEXION 480



LEXION

You can fine tune the LEXION perfectly to any harvest.

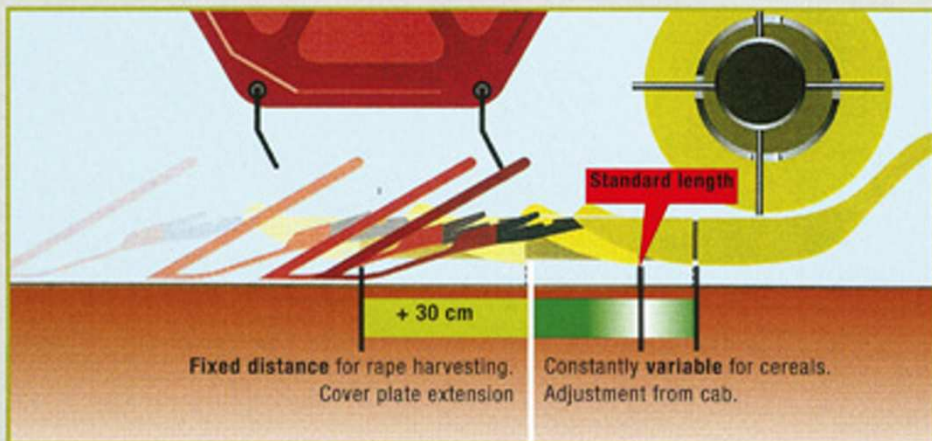

The cutter bar determines the combine's output.

The crop must enter the threshing system in an even flow if you are to achieve the highest output, lowest fuel consumption and have a smooth running machine. These are the basic parameters in achieving high overall efficiency on a modern combine.

Push button flexibility.

The VARIO cutter bar was developed for situations where the table width needs to be adjusted on the go. A shorter table width is useful in short barley, whilst it should be wider in high yielding wheat and long stemmed rye. The setting is changed at the touch of a button in the cab in a range from 100 mm shorter to 200 mm longer. This enables a consistently high crop flow to the threshing drum in all conceivable conditions, raising the combine's performance and improving your operating economics.

Quick change from barley to rape harvesting.

With additional cover plates across the width of the cutter bar table, the VARIO cutter bar can be extended still further without the need for any tools to harvest OSR. After being lengthened by 500 mm, the lateral knife set is fitted and the LEXION 480 is ready to cut the rape. This is a time saving approach and makes it unnecessary to invest in an extra rape cutter bar. The optional CLAAS cutter bar trailer also has a compartment to store the filler plates and lateral knives.



Hydraulic reel drive.
Badly lodged crops and wide cutter bars place heavy demands on the reel. The new hydraulic drive from CLAAS gives it the extra torque and rapid control needed for good results.



Consistent crop intake.
The controlled multifinger tines across the full auger width plus the high auger flights feed the crop smoothly to the conveyor in all conditions, keeping the threshing drum fully employed all the time.



In case of blockage.
The hydraulic reverser drives the feeder housing and the cutter bar or maize header. The hydraulic motor generates high torque for clearing blockages quickly.

Intelligent cutter bars.

AUTO CONTOUR is the automatic cutter bar guidance system which makes the combine much easier to operate over any terrain. It also reduces the entry of stones and contributes to higher work rates, particularly when conditions get tricky. The LEXION 480 goes a step further – AUTO CONTOUR plus automatic reel control and CEBIS link. That means AUTO CONTOUR actively

manages the height, sideways angle and ground pressure of the cutter bar and in addition it matches the reel speed to the travel speed. How does it work? All the time the combine is working, the actual values are compared with the selected settings and the electronic system regulates everything via the hydraulic system.

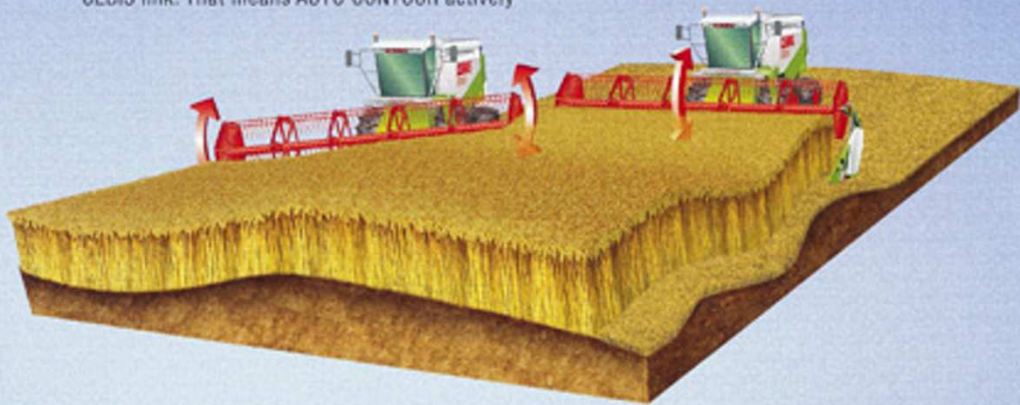

More efficiency gains: the LEXION 480 with the LASER PILOT.

Automatic steering in the cereals harvest.

The LASER PILOT adds to output in all conditions by relieving the driver of a tiresome job, especially with extremely wide cutter bars. Now, the driver can take a drink whilst driving, call up for extra trailers or check what job to do next. The operator has plenty of time to check the returns and fine tune the combine to keep it running at the limit all the time. The discharging operation is also made much easier when you don't have to keep your hands on the steering wheel.



20:20 vision

with LASER PILOT installed, the edge of the standing crop is identified by pulses of light. The system can recognise the dividing line and steers the combine automatically along this line. The full cutter bar width is utilised since the LASER PILOT doesn't need the same safety margin a driver requires. That translates into fewer passages across the field, lower fuel costs and more accurate yield mapping.

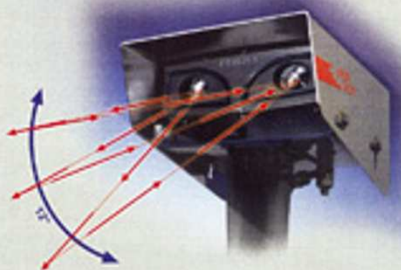

The LASER PILOT sees everything. This black box above the cutter bar houses the LASER PILOT's optical nerve centre. The light emissions can see well in darkness, mist and weed filled crops.

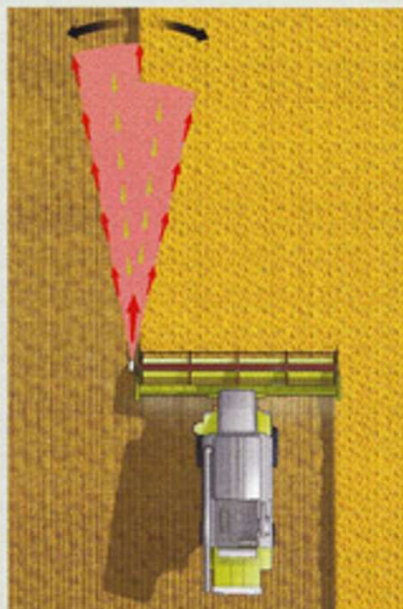

What's the trick?

The light that hits the stubble takes longer to reflect back than from the standing crop. The LASER PILOT can identify the edge of the crop with this tiny time difference, using the left hand edge of the cutter bar as the reference point.

An award winner.

The CLAAS LASER PILOT has won many awards including the coveted AGRITECHNICA gold medal in 1999.

APS
System

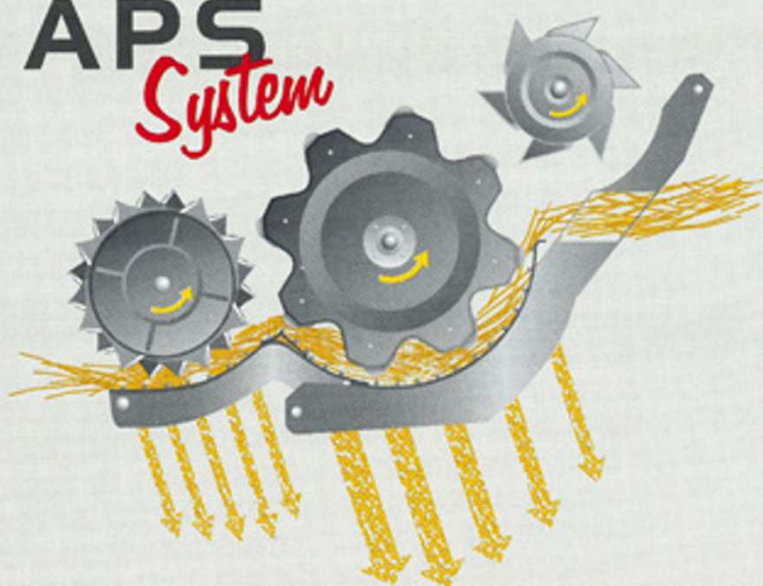

APS speeds up the crop for more throughput.

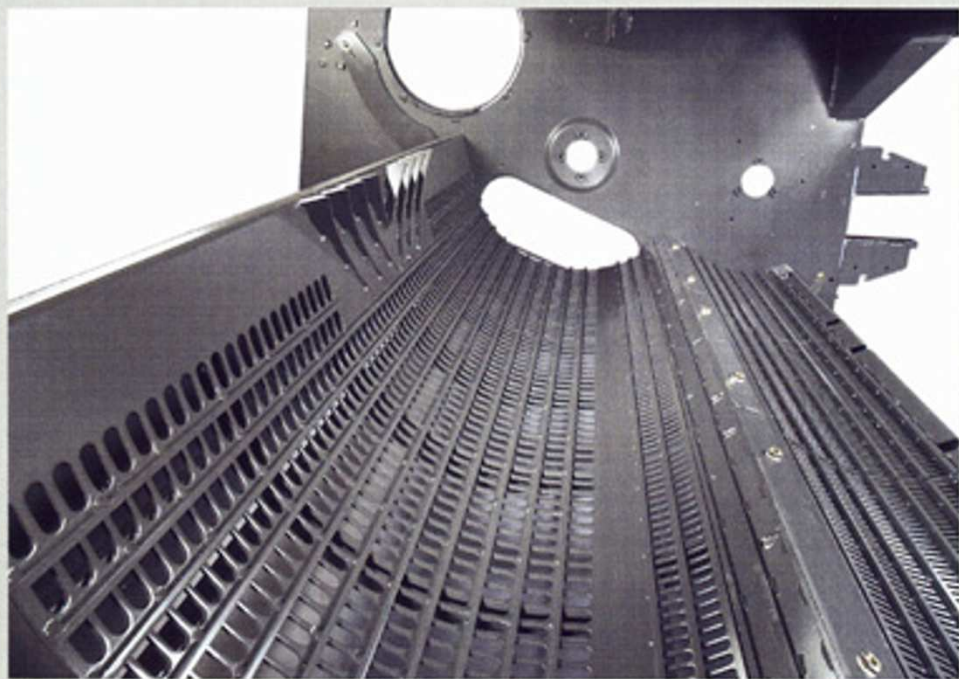

Proven in the field.

Since its introduction some years ago, the APS threshing system (Acceleration and Preseparation) has established a fine reputation. Many cite the CLAAS APS system as the most important breakthrough in combine design in the last twenty years.

A smooth crop flow.

The accelerator drum ahead of the main threshing drum creates a crop flow that is more consistent and a lot faster than usual with an increased centrifugal effect. This, plus a doubling of the concave area, means much higher separation efficiency and output. The threshing drum is 1.70 metres wide and 600 mm in diameter, a really

big unit for maximum performance. Thousands of satisfied users confirm that this system is the finest available.

Performance and quality.

The APS design is a harmonious unit and ensures that the crop is passed on smoothly. The impeller runs at the same speed as the threshing drum. This is aimed at maintaining the even crop flow and treating the crop gently. The threshing drum speed and concave setting are both set using CEBIS, either automatically or with the driver's own values.

Exclusive

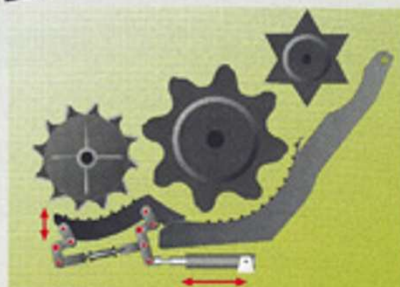

Comfortable control from the cab. The APS concaves are finely adjusted in parallel from the driver's seat with an electro-hydraulic control. The hydraulic cylinders also safeguard the concave against overload, so the LEXION 480 driver can work at the limit all day without any risk. This translates into higher acreage.



Multicrop features cut costs.

The LEXION 480 accelerator drum concave is divided into three segments that can be changed over easily. Large and small grains can all be harvested with a minimum of delay. The wide spacing of the concave slats makes it possible to thresh every type of crop.



Dependable drives.

The power flow on the LEXION 480 is outstanding. A clean design that transfers the high power requirements reliably to where it's needed.

CLAAS



The LEXION 480 – highest output of all.

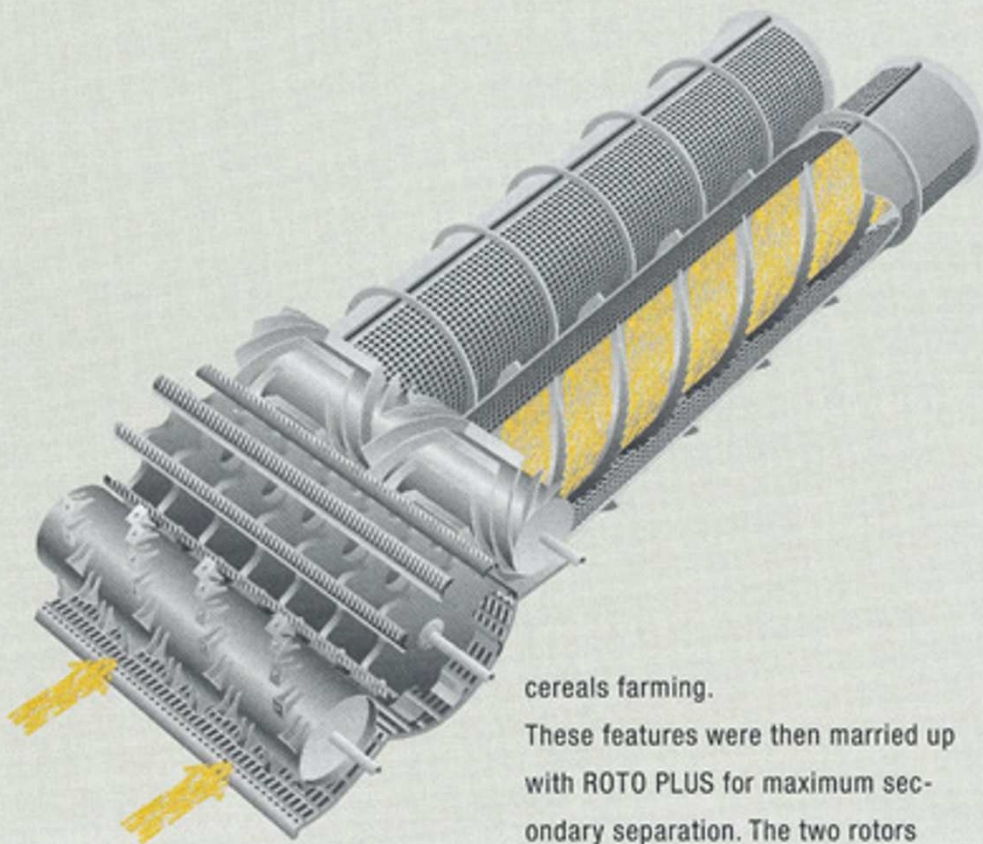

Innovation breaks the performance barrier.

Remarkable synergy effects were achieved by combining two excellent component groups. This is what happened when the APS threshing unit was paired up with the secondary separation rotors and new levels of performance are the result.

A winning combination.

The highly efficient APS system has been further enhanced on the LEXION 480 and this sets the scene for high performance combining. It produces first class primary separation in all types of crop and can cope with the large volumes of green, damp straw which have become part of modern

cereals farming.

These features were then married up with ROTO PLUS for maximum secondary separation. The two rotors counter rotate to extract every last grain from the straw. The results are impressive over the long passage through the rotors with a clean crop which is both gently handled and fully separated. The rotors are designed solely to separate the crop, making them highly effective with a steady output curve as the graph shows.

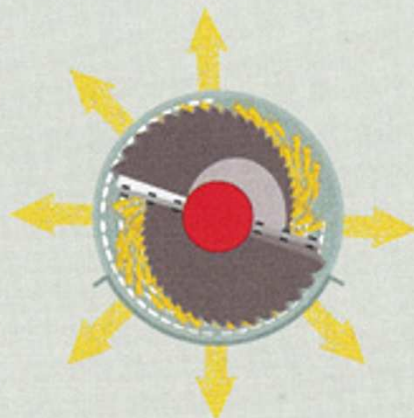
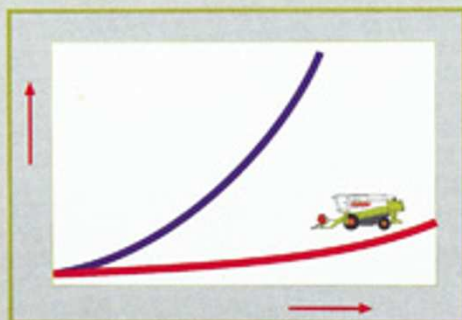

Thorough secondary separation.
The chevron impeller divides the crop into two streams and feeds them to the rotors. The auger flights on the rotors then feed the straw to the back mixing it all the way along, whilst high centrifugal forces extract the last grains buried in the straw.

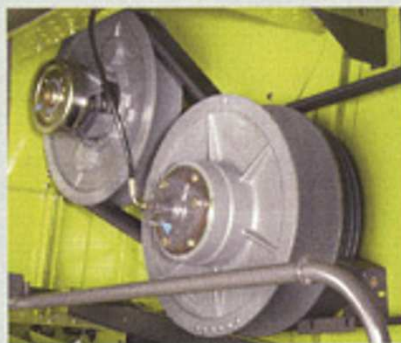

Adjustable rotor speed.
The rotor speed can be modified to suit different crops and harvesting environments with the optional stepless speed variator. This provides a rotor speed range from 360 to 1050 rpm.



Baled straw – a valuable by-product

Straw is frequently baled after combining for use in farming as bedding material for horses, cattle, pigs or poultry. The standard straw chopping system can be switched off at the touch of a button, enabling the straw to pass through the two distribution fans, after which it is spread in an even swath on the field.

Take a look at the straw left behind the LEXION 480 and you will see that it retains its structure and is opened up very little. This is a sign that the crop has been threshed gently. There is little chaff produced, so the cleaning system is not overloaded unnecessarily,

increasing performance once again.

The swath is fluffy and dries out quickly, so it can be made into any type of bale shape as needed.





Chopped straw – evenly spread

Meeting the demands of modern farming.

Working the straw back into the soil is an integral part of modern tillage. However, successful no till or minimal tillage farming entails chopping the straw up finely and then spreading it evenly across the full cutting width. You can lay the foundations during the harvest for a successful crop the year after with the unique LEXION 480 straw chopping system.

First rate straw management.

The straw is fed from the rotors directly to the chopper. A short chop is

ensured by the closely arranged knives, the shear bar and the counter-blades. Chaff and debris from the sieve box join up with the chopped material and the mixture is accelerated by the two fans, following which it is ejected and spread evenly across the field with a to and fro movement produced by a hydraulic cylinder acting on the blower chutes. The width is adjustable from the driver's seat so that changes in straw composition, cross winds and slope angle can be compensated for.

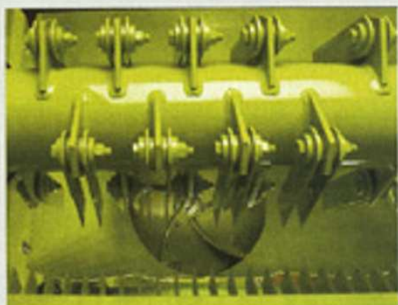

A uniformly short chop.
As it leaves the rotors the straw is chopped up, mixed with the chaff and blown onto the field.

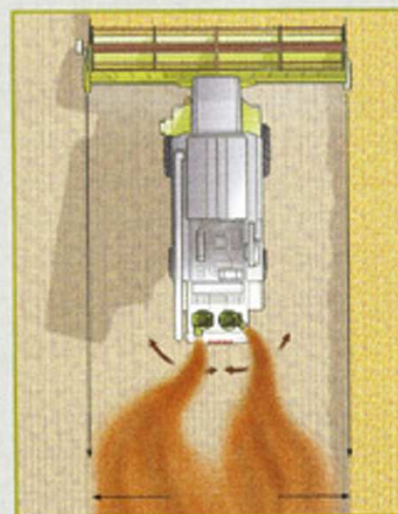

Swivel action spreading.
The chopped straw is spread evenly by means of a swivelling blower chutes. The range can be varied up to 9 metres behind the combine, depending on the cutting width.



Gone with the wind – in 3D if you prefer.



Full utilisation of tank capacity.

The huge grain tank contains a full 10,500 litres. Every corner is properly utilised and the driver can check the crop quality by looking through the rear cab window or taking a sample from the opening next to the cab. The turret auger is designed for a high volume discharge rate onto high sided trailers. The 101° swivel angle helps the driver keep an eye on what's happening when discharging in parallel, adding to continuous high throughput of the combine.



Set up from the cab.

The correct air blast, sieve box settings, concave spacing and threshing drum speeds are all set from the cab with the aid of CEBIS.

Levelling every slope.

The LEXION 480 can of course be equipped with CLAAS 3 D dynamic slope compensation. This dynamic slope compensation ensures that the crop stays spread across the full sieve box width and doesn't get piled up on the downhill side. Every field has some kind of slope on it, often not noticeable to the driver but resulting in crop drift and increased losses. 3 D uses hydraulics to stop the losses efficiently, even on slopes of 20%. With a simple maintenance free design it's the envy of the competition.



A strong air blast ensures crop quality. The large width of the LEXION 480 demands a strong air blast to keep the sieves well ventilated. This combine has huge 6 section turbine fans fitted.



Crop checking any time.

The driver can check the make up and volume of the returns to the right hand side of the cab, so the sample is clean all the time.

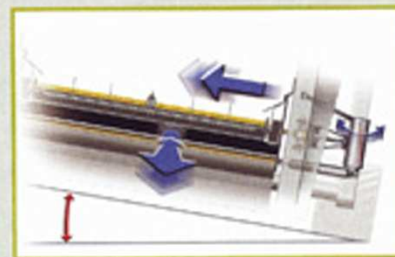
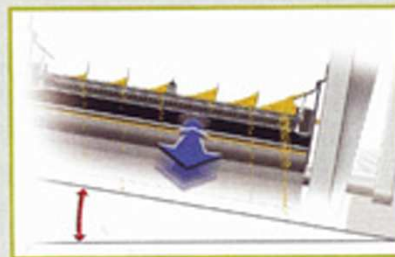

Full speed across slopes.

The CLAAS 3 D slope compensation for full time top throughput. Every slope, however small, reduces output on conventional machines. On a 10% slope, output is cut by one third. Not so with the ingenious and simple 3 D system, unique to CLAAS and fully effective on slopes of up to 20%.

The power to succeed.

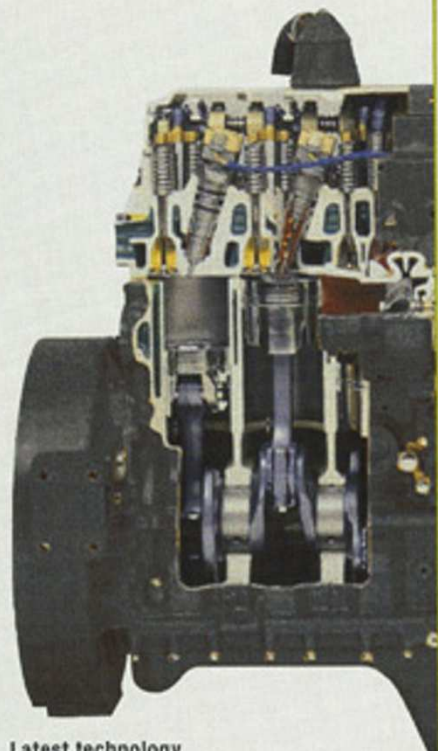

Latest technology

The C12 engine has a gross output of 317 kW / 431 hp at 2100 rpm and is designed with plenty of torque back up so it doesn't run out of steam in extreme situations. It is equipped with new generation four valve technology. Each cylinder has its own fuel pump. The engine management system controls the fuel metering solenoids so that the amount of fuel injected is exactly right for the prevailing conditions. This is a key prerequisite for full energy utilisation, leading to surprisingly low fuel consumption.

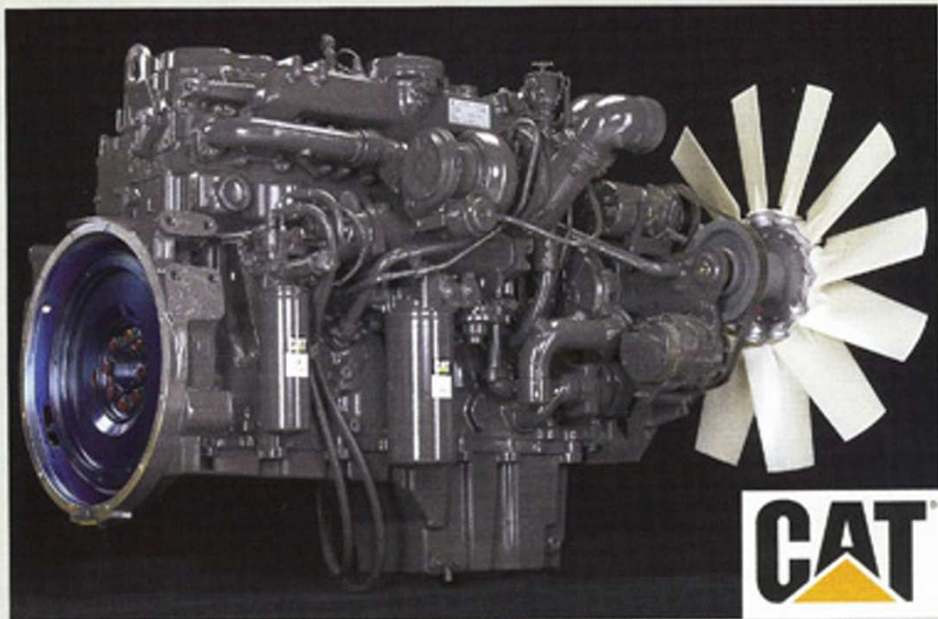

The annual endurance test.

The LEXION 480 is fitted with a Caterpillar engine. Caterpillar is the world's largest manufacturer of industrial diesel engines and they are used widely in highly demanding road building, mining and truck applications. These engines feature rugged design and extreme slogging characteristics, whilst they also comply with all current emission standards.

Electronic engine management.

The system monitors all the operating data continuously, making sure every gram of fuel gets turned into power and not wasted. Fuel efficiency that contributes to the excellent operating economics of the combine and an optional fuel consumption display for effective control of fuel costs.

Easy access.

The engine is located behind the grain tank, where it is reached conveniently for maintenance jobs from a service platform at the rear. The drives are logically spread along both sides of the machine, with the aim of achieving a balanced load and power distribution.



Full mobility on tracks.



The track advantage.

As a combine gains in weight, this has to be spread across the surface of the tyres. This in turn is limited by the width available on the road. Where tyres have reached their limits, the CLAAS rubber belt drive option takes over.

A large footprint.

The track dimensions are configured to keep the LEXION 480 combine within road width limits. The width of the combine is just 3.50 metres. The large contact area compared to normal tyre type combines means that ground pressure can be cut down substantially with positive effects on the soil structure. As soil conservation gains in importance, this factor alone may be a

decisive factor in favour of the LEXION 480. For harvests later in the year, the operating window is greater, so added hours can be clocked up, in maize for instance. The driver has the same control layout, so there's no need to get used to unusual driving modes.

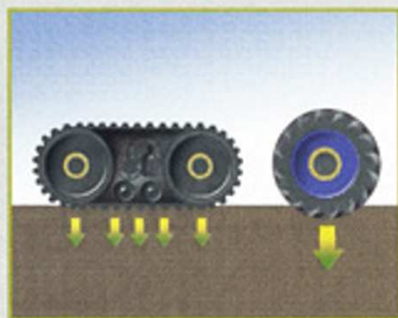

Low ground pressure.

The significantly increased contact area of the tracks cuts ground pressure to a minimum and retains full mobility over soft fields.



Wide profile tyres improve traction. High flotation tyres are an alternative, and they too can lower ground pressure.



The first class operator's environment.



with a pleasing choice of colours and materials. The seat is the most comfortable available and it is adjustable for both the height and weight of the driver. The steering column is also fully adjustable with countless angle, height and tilt settings.

A cool environment.

The driver can set the air flow to suit personal preferences. Large filters stop the dust from getting in, so only clean air is inhaled. The automatic climate control goes a step further in perfecting the operating conditions for the driver.

Getting close to perfection.

Any number of research projects is available to prove that a stress free operator's environment contributes to higher output and fewer mistakes. For this reason CLAAS engineers place great emphasis on the cab. The VISTA cab puts the driver on centre stage with huge expanses of glass and a clear view over the cutter bar.

Relaxed driving.

The interior has a modern look to it



The cab that leaves nothing to be desired. Radio and two way radio pre-installed. Plenty of light inside for working at night. Snacks and drinks are kept cool in the cool box, and are easily reached whilst driving.



Room for two. A buddy seat is fitted in case somebody needs to ride along, for instance when a new driver is being shown the ropes.



The most advanced control philosophy.



A single lever with numerous functions.

The new style multifunction control lever manages travel speed and direction, plus cutter bar and reel functions. The lever is integrated into the right hand armrest, so it's always in the same position relative to the driver's seat.

Latest electronics.

CLAAS CEBIS is the communications interface on the LEXION 480. A wide range of functions is monitored with correctional action taking place quietly in the background, as conditions change.

Electronic set up and adjustment.

CEBIS also manages the whole combine set up. Threshing drum speed, concave spacing, sieve opening and air



flow can be set to pre-installed default values or modified individually. You can file your preferred settings and call them up whenever you like.



One glance control.
This large CEBIS display next to the driver's seat shows all the key operating data of the combine.



The PCMCIA card
records the main job related data.



Analysis.
Each daily report can be filed and analysed at leisure on the farm office PC.



agrocom.

the name for perfect farming

on board

A powerful partnership: LEXION yield mapping and AGROMAP Start.

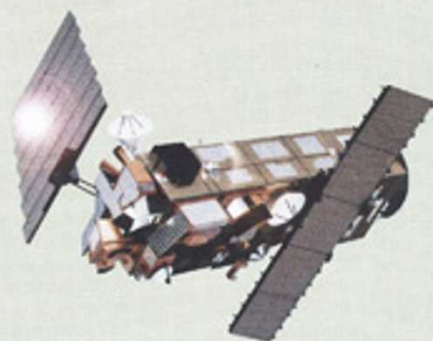

LEXION yield mapping and AGROMAP Start in the double pack.

AGROMAP Start is the software designed to help you make informative yield maps. During the harvest with the LEXION combine CEBIS measures the specific yields with a high level of accuracy. AGROMAP Start analyses these values and constructs the yield map. The differences in yield provide valuable clues to enable you to plan seeding densities, crop protection and fertiliser application. Additionally, AGROMAP Start supports damage documentation and area measurement.



User friendly, mature technology.

AGROMAP Start has been designed by Agrocom to get you started on precision farming. The menu layout is ideal for novices and a modular approach allows you to go further with precision farming at your own pace. Data storage and retrieval on the chip card with

the CEBIS on-board computer is particularly easy. The screen is clearly laid out and the files only contain functions of direct value to the user at any particular time.

New style farm management on the screen.

Yield mapping is the most secure way of getting the most from the farm in future. It puts you in the picture regarding yields and variations, it supports soil tests, shows up treatment options and monitors the success of your actions. You can check out the performance of a driver, analyse each field and even the whole farm and you can call up the yield maps at the touch of a button.

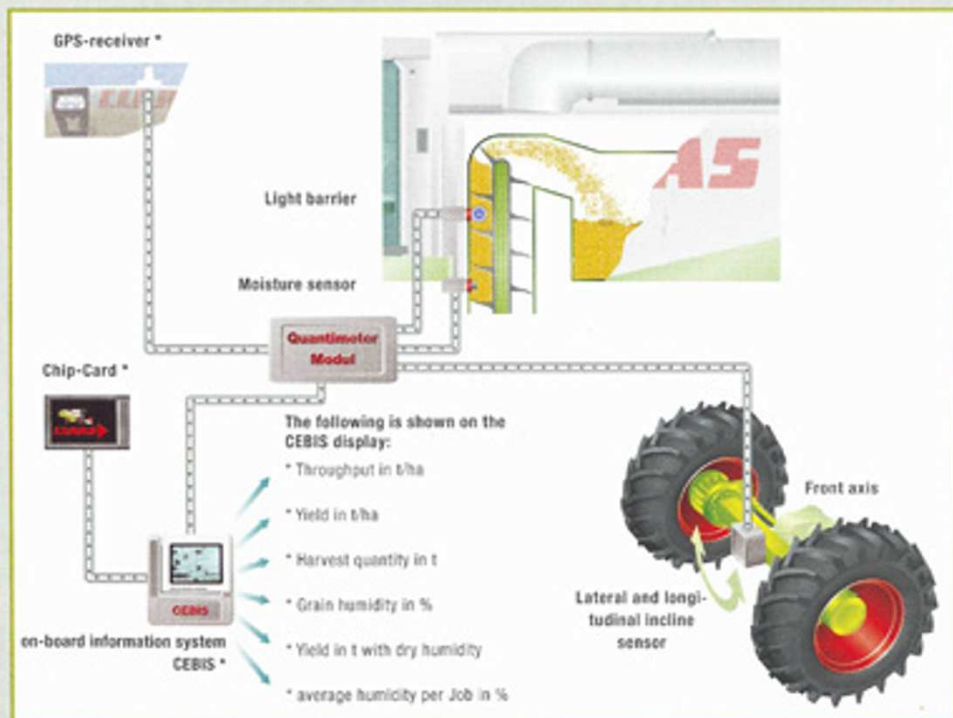

With CEBIS all data can be printed out

*GPS is included in the delivery scope, and DGPS is also available as an option.

From data collection to the yield map. Optical sensors measure the height of the crop on the elevator paddles. The dry yield is calculated based on the partial filling and the grain moisture level. The slope angle of the combine has no influence on this measurement. A chip stores the data along with the position determined by the GPS satellites. Back in the office, this data is transformed into precise yield maps by way of the AGROMAP Start software.

CLAAS





LEXION 480 – the right combine for maize harvesting.



Easy changeover.

Maize or corn harvesting is a vital part of the job in most parts of Europe and the USA, so CLAAS has its own maize header range to go with the LEXION 480. The new 6 and 8 row CONSPEED headers have been designed to match the output of the LEXION 480. Fitting and removal is done by the same multilink connector as for the cereals cutter bar.

High picking standards.

The CONSPEED headers are unique in having tapered snapping rolls. They increase throughput whilst treating the cobs gently. The stalk is initially pulled down slowly until the cob is cleanly severed. The stalks can be chopped and spread evenly across the field if needed. This option makes it

possible to start tillage immediately after the harvest.

Full of new ideas.

The plastic cover plates are extra slim so that even hanging or laid maize stems are picked up. The LEXION 480 doesn't miss any of the plants. Easy access to all the components is another important feature whilst it's easy to replace the snapping rolls when the time comes.



Choose between 6 and 8 rows. The CONSPEED range are always a good choice when speed, efficiency and low cost are called for.



Gentle picking, clean chopping. The cob is handled gently on its way to the snapping rolls. Only then is the stalk speeded up and chopped up by the horizontal knives under each tapered picking unit.



Proven AUTOPILOT steering. Two sensor rods in one of the picking units locate the position of the combine in the rows of maize and steer the LEXION 480 across the field with no losses, even when the visibility is poor or at high travel speeds. The driver can sit back and fine tune the combine.



Easy road travel. The two outer picking units can be folded in to a width of 3 metres from the cab hydraulically. When being folded out again, all the components slide into engagement again so you save as much time as possible.

CLAAS



Specifications. LEXION 480

Cutter bar widths	m	6.60 / 7.50 / 9.00
Folding dividers		Standard
Distances of knives to intake auger	mm	580
Cutting speed	strokes/min	1120
Multifinger intake auger		Standard
Hydraulic reel speed adjustment	rpm	8 to 60
AUTO CONTOUR guidance system		Standard
Automatic, speed / height system for reel		Standard
Accelerator running at 80% of drum speed		Standard
Width of multicrop threshing drum	mm	1700
Threshing drum diameter	mm	600
Drum speed		
- without reduction gear	rpm	362 to 1050
Drum speed		
- with reduction gear	rpm	158 to 457 / 360 to 1050
Peripheral drum speed		
- without reduction gear	m/sec	11,4 to 33,0
Peripheral drum speed		
- with reduction gear	m/sec	5.0 to 14.4 / 11.4 to 33.0
Synchronised impeller		Standard
Automatic torque sensing drum drive		Standard
Wrap angle		
- preparation concave	degrees	90
Wrap angle		
- main concave	degrees	142
Electro-hydraulic concave adjustment with overload protection		Standard
ROTO PLUS rotor separation		Two rotors
rotor speeds	rpm	960 / 800 / 640 / (500)
or with optional variator	rpm	360 to 1050

Quality from Harsewinkel

Harsewinkel is the centre of combine development within the CLAAS Group and is also its prime manufacturing location. From here, close contacts are maintained with customers and at harvest time, CLAAS engineers are out in the field, learning how to do things even better at first hand. State-of-the-art manufacturing methods ensure that CLAAS quality stays at a consistently high level. New generation computer aided design and production systems give a unique touch to every CLAAS product. Service and parts supply are of vital importance and set the standards in the business. All round reliability means peace of mind for your harvest.



Rotor length	mm	4200
Rotor diameter	mm	445
Cleaning		
Total sieve area	m ²	5.80
Electrical sieve box adjustment		Standard
Fans		Turbine, 6 segments
Electrical fan adjustment		Standard
Divided sieve box		Standard
Double ventilated step		Standard
Removable preparation pan		Standard
3 D slope compensation		Standard
Returns monitoring to		
accelerator visible from cab		Standard
Grain tank	volume	10.500
Discharge speed	l/s	100
Discharge auger swivel range	degrees	101
QUANTIMETER yield metering		device
- with yield mapping		Optional
Turret auger discharge height	mm	4450
Engine model		Typ CAT C12
Maximum power at 2100 rpm	kW/PS	317/431
Effective power to		
DIN or ECE R 24 at 2100 rpm	kW/PS	303/412
Fuel tank contents	l	830
Transmission		Hydrostatic
Front tyres		650/75 R 32, 680/85 R 32, 710/75 R 34, 800/65 R 32, 900/60 R 32, 1050/50 R 32, 18.4 R 38 dual
Rear tyres		16.5/85-24 500/70 R 24, 600/55-26.5,



CLAAS products are subject to continuous improvement, so changes are possible without notice. All descriptions and specifications in this brochure should be considered as approximate and may include optional equipment which is not part of the standard specifications. This brochure is designed for world-wide use. Please refer to your nearest CLAAS dealer and their price list for local specification details. Some protective panels may have been removed for photographic purposes in order to show the functioning more clearly. All machines comply with cur-



CLAAS

CLAAS KGaA mbH

P.O Box 1163,

D - 33426 Harsewinkel

Tel. +49 (0) 5247 12-0

Internet: <http://www.claas.com>

08/02 (Rihn) englisch 30/190 407.4

